

**CONFIDENTIAL**  
CUSTOMER CONTROLLED DOCUMENT

SPECIFICATIONS	SPEC NO
MATERIAL	M-029

REVISIONS					
REV	DESCRIPTION	DCN NO.	DATE	BY	APPV.
P	REVISE TITLE BLOCK/REVISE CERTIFICATION NOTE	O-7318	09/17/93	NW	CLL
Q	REVISED NOTE 5	O-7318	09/21/93	NW	CLL

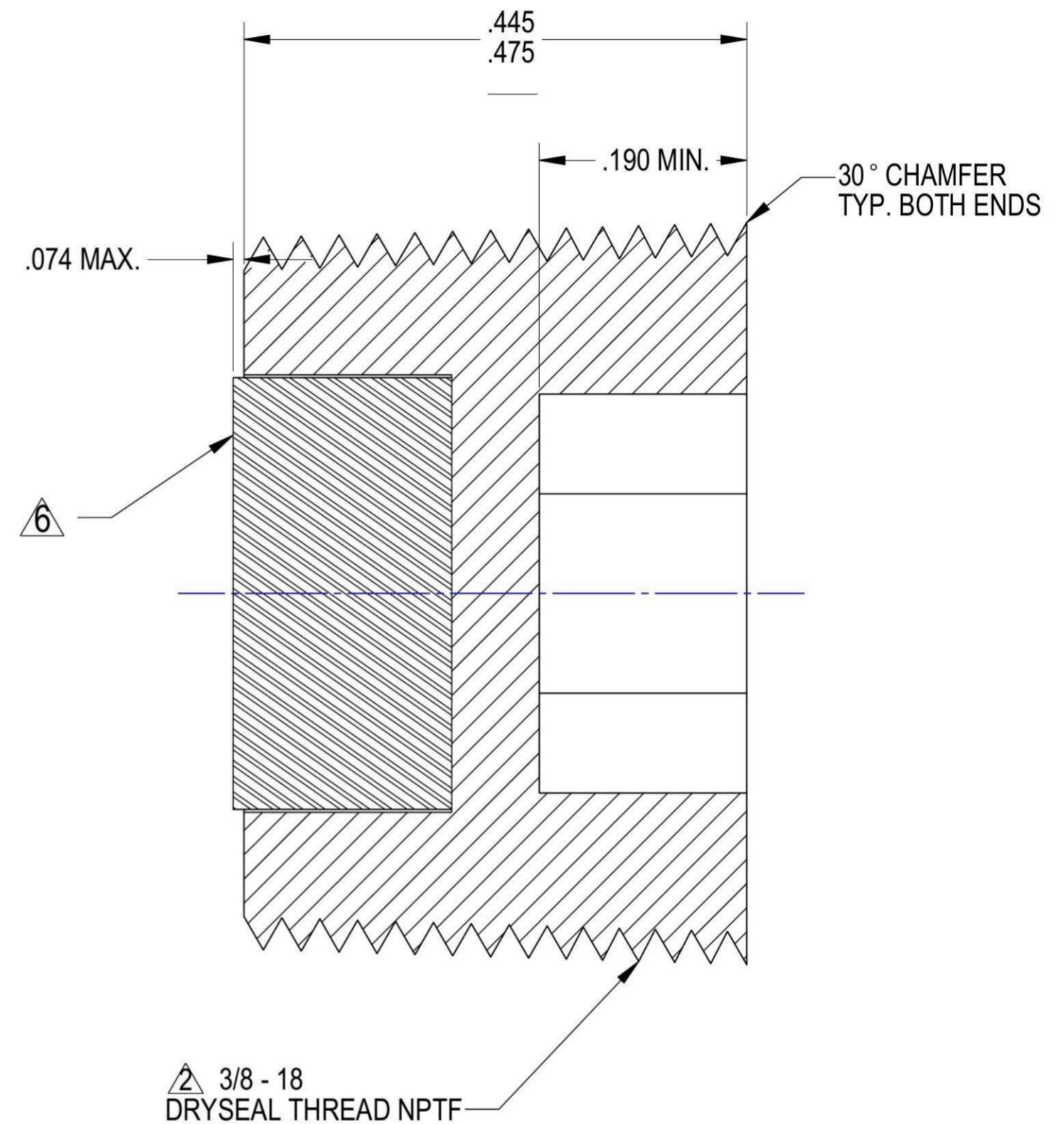
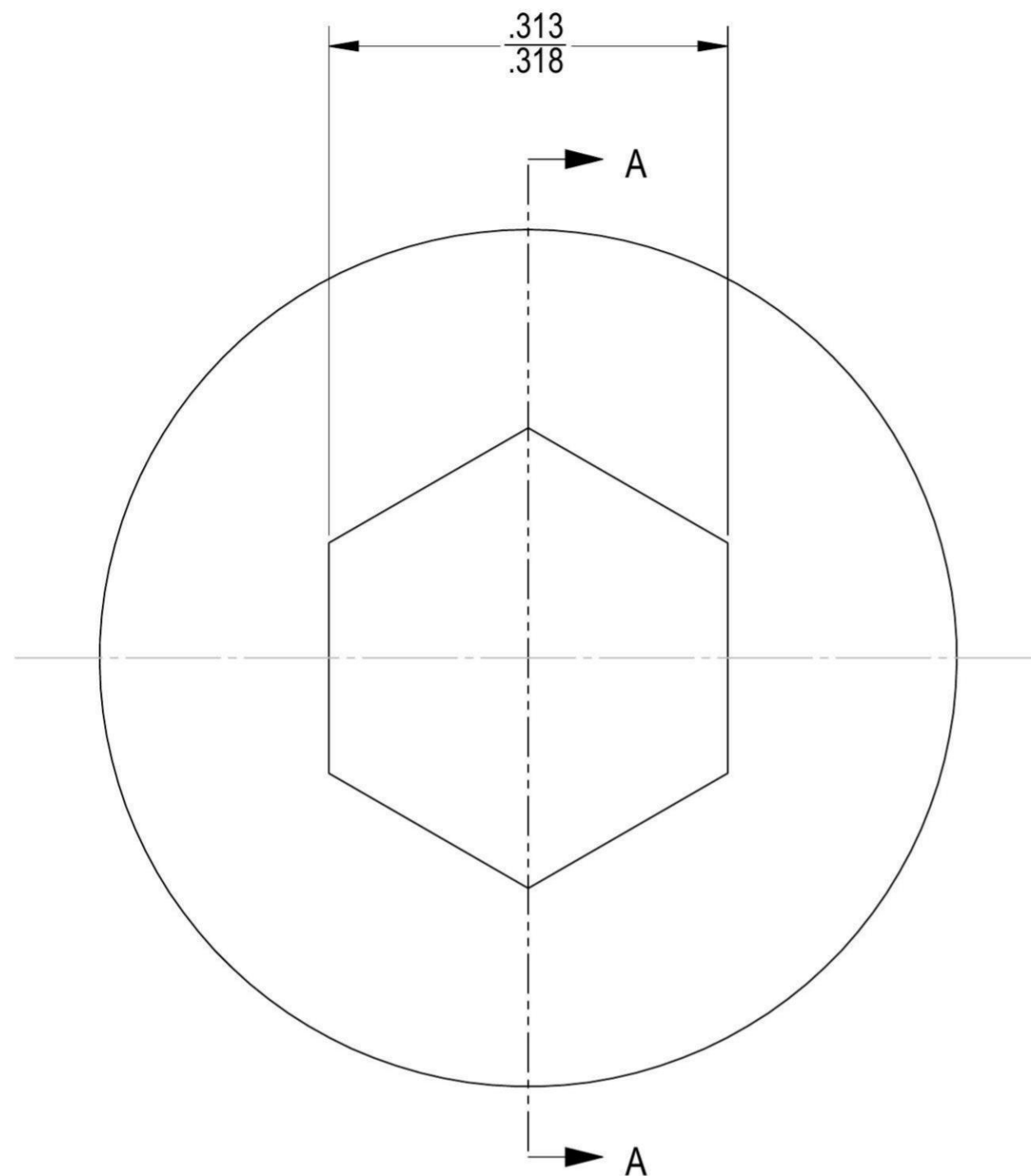

**SECTION A-A**

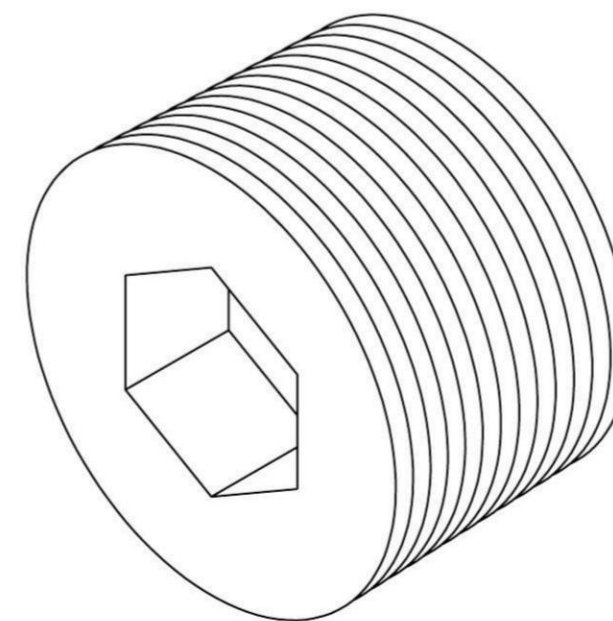

**NOTES:**

1. MIN SPEC. SAE J531a.
2. FOR ADDITIONAL THREAD AND GAGING SPECIFICATION SEE SAE J476a.
3. MATERIAL: SAE 1005-1025 OR AISI 4037/ 4137 STEEL.
4. FINISH: BLACK OXIDE, ZINC, OR CAD PLATING. THREAD TO BE COATED WITH SEALANT PER MATERIAL SPECIFICATION M-066.
5. CERTIFICATION OF COMPLIANCE REQUIRED.
6. Y34 CERAMIC I MAGNET RETAINED WITH 3M EPOXY (EC-2214).

QTY	PART NO.	DESCRIPTION	QTY.
1	08219W203	STRAIGHT O.D. TUBE	1
1	092290224	SHORT RADIUS ELBOW	1

BILL OF MATERIAL

PROPRIETARY- This information is confidential. It contains proprietary information and other rights which are the sole and exclusive property of [redacted]. Possession of this material does not convey or transfer any rights thereto, and any reproduction, use, copying, or disclosure to others is forbidden without the prior written consent of [redacted].

TOLERANCES UNLESS OTHERWISE SPECIFIED	DRAWN: RAL	PART NAME	PIPE PLUG, 3/8"	
ANGLES ± Q°	DATE: 10/29/99	SCALE	SIZE	PART NUMBER
(XX) ± .010	APPV:	NONE	A	033595984
(XXX) ± .005	DATE:			REV
				Q